



BUILT FOR INDUSTRY. DESIGNED TO PERFORM.



SMOOTH  
CONVEYING



STURDY &  
DURABLE



EASY TO  
INTEGRATE



LOW  
MAINTENANCE

## DIMENSIONS

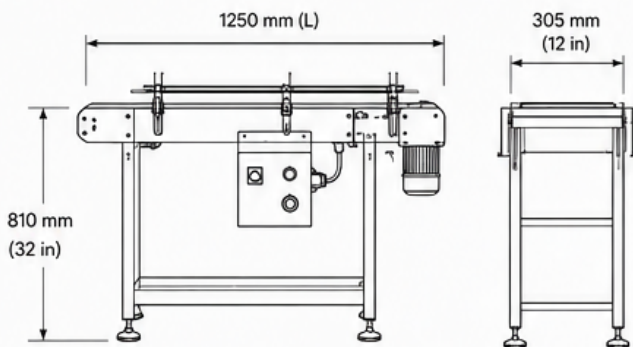

\* All dimensions are approximate.

Total Dimension:

1.25 Meter X 12 Inch X 32 Inch (L X W X H)

## SPECIFICATIONS

1. Total Dimension: 1.25 Meter X 12 Inch X 32 Inch (L X W X H).
2. Industrial Profile Top and Full SS 304 Grade 40 mm X 40 mm tubular Matt Finish structure and platform.
3. Variable frequency Drive Three phase to single phase.
4. S.S. panel with speed control, START / STOP Operation.
5. S.S. Fixed guide for product alignment.
6. Nylon leveling base 80 mm.
7. AC Synchronous conveyor geared motors 0.5 hp.
8. Single phase 240 V Main supply with 3-meter flexible cable for power supply.

## IDEAL FOR



PACKAGING



INSPECTION



SORTING



ASSEMBLY



MATERIAL  
HANDLING



PREMIUM QUALITY  
SS 304 Construction



RELIABLE PERFORMANCE  
Built for Continuous Operation



ENERGY EFFICIENT  
Low Power Consumption



CUSTOM SOLUTIONS  
Tailored to Your Needs